



Remote I/O Adapter Module

(Catalog Number 1747-ASB)

Inside	page
Hazardous Location Considerations	2
Environnements dangereux	2
1747-ASB Module Overview	3
Required Tools and Equipment	4
Determining System Power Requirements.....	4
Slot Addressing.....	5
Configuring the Module	6
Installing the Module.....	10
Connecting RIO Link Devices	11
Wiring a Processor Restart Lockout Switch	14
Installing I/O Module Addressing Labels	15
Performing System Start-up	17
Checking Operation.....	17
Specifications	18
For More Information	19

Hazardous Location Considerations

This equipment is suitable for use in Class I, Division 2, Groups A, B, C, D or non-hazardous locations only. The following WARNING statement applies to use in hazardous locations.

WARNING



EXPLOSION HAZARD

- Substitution of components may impair suitability for Class I, Division 2.
 - Do not replace components or disconnect equipment unless power has been switched off or the area is known to be non-hazardous.
 - Do not connect or disconnect components unless power has been switched off or the area is known to be non-hazardous.
 - All wiring must comply with N.E.C. article 501-4(b).
-

Environnements dangereux

Cet équipement est conçu pour être utilisé dans des environnements de Classe I, Division 2, Groupes A, B, C, D ou non dangereux. La mise en garde suivante s'applique à une utilisation dans des environnements dangereux.

AVERTISSEMENT



DANGER D'EXPLOSION

- La substitution de composants peut rendre cet équipement impropre à une utilisation en environnement de Classe I, Division 2.
 - Ne pas remplacer de composants ou déconnecter l'équipement sans s'être assuré que l'alimentation est coupée.
 - Ne pas connecter ou déconnecter des composants sans s'être assuré que l'alimentation est coupée.
-

1747-ASB Module Overview

The 1747-ASB module is an SLC 500 single-slot, RIO communication link module. It occupies the first slot (slot 0) of a 1746 remote chassis, where the SLC processor normally resides.

The 1747-ASB module is an adapter, or slave, on the RIO link, and the master of the remote chassis and remote expansion chassis in which it is installed. *Remote expansion chassis are optional.* The module acts as a gateway between the scanner and the I/O modules residing in the remote chassis and remote expansion chassis. It maps the image of the I/O modules in its remote chassis and remote expansion chassis directly to the SLC or PLC processor image.

Output data is sent from the scanner of either the SLC or PLC local chassis to the 1747-ASB module across the RIO link. This data is automatically transferred to the output modules across the chassis backplane by the 1747-ASB module. Inputs from the input modules are collected via the backplane by the 1747-ASB module and sent back to the scanner across the RIO link. No user programming of the 1747-ASB module is necessary.

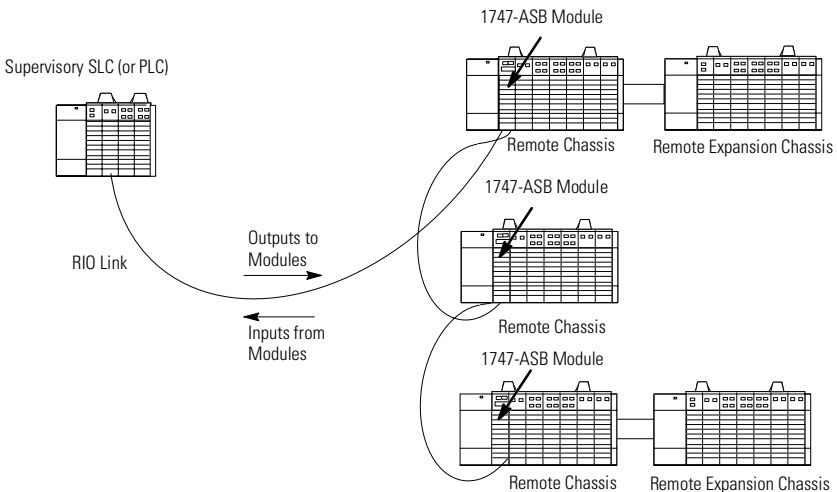

Hardware Features

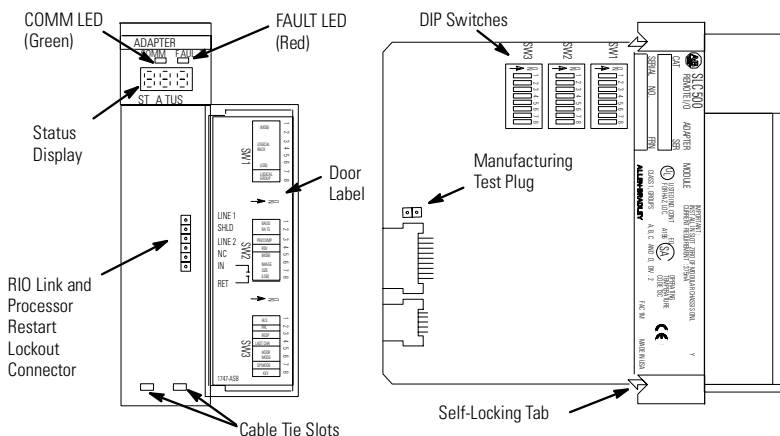

Required Tools and Equipment

Have the following tools and equipment ready:

- medium blade screwdriver
- (2) 1/2 watt terminating resistors (See page 18 for correct size.)
- an adequate length of RIO communication cable (Belden™ 9463) for your specific application. (See page 18 for maximum cable distances.)

Determining System Power Requirements

Review the power requirements of your system to ensure that the chassis supports placement of the 1747-ASB module. The adapter consumes 600 mA at 5V dc. For a detailed list of device load currents, refer to the *SLC 500 Fixed Hardware Style Installation and Operation Manual*, publication number 1747-6.21; the *SLC 500 Modular Hardware Style User Manual*, publication number 1747-UM011, or the appropriate Technical Data sheet.

Slot Addressing

Slot Numbering

The 1747-ASB module is capable of controlling 30 slots. When expansion chassis are used, the 1747-ASB module treats all of the I/O modules as if they are installed in a single chassis.

The remote chassis and remote expansion chassis slots are numbered from 0 to 30. The 1747-ASB module *must* reside in slot 0. Slots numbered 31 and above cannot be used.

IMPORTANT

Installing modules in slot 31 or above results in a module error.

Addressing I/O Modules

SLC and PLC processors address the I/O modules residing in the chassis by logical rack and logical group. Slot addressing refers to how each chassis slot is assigned a specific amount of the 1747-ASB module image. The amount depends on which type of slot addressing you choose; 2-slot, 1-slot, and 1/2-slot addressing is available, as shown below.

IMPORTANT

Due to SLC and PLC addressing differences, when the 1747-ASB module is used with an SLC processor, the image bit numbers are 0 to 7, 8 to 15 decimal. When the 1747-ASB module is used with a PLC processor, the image bit numbers are 0 to 7, 10 to 17 octal.

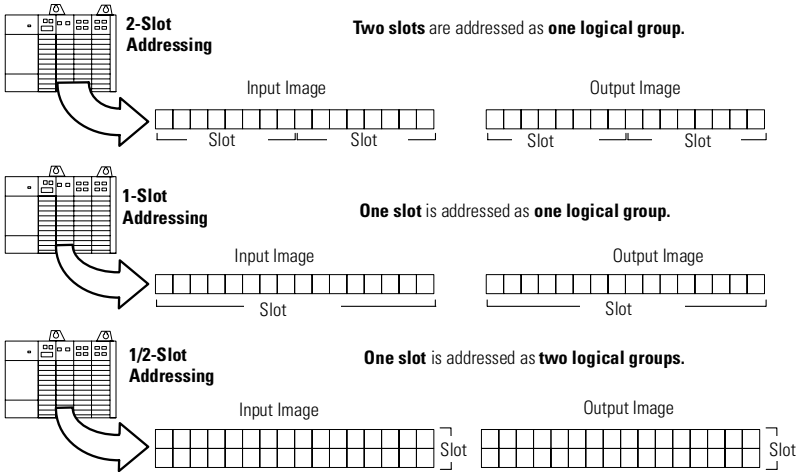

For more information on addressing, refer to the *Remote I/O Adapter Module User Manual*, publication number 1747-6.13.

Configuring the Module

The 1747-ASB module parameters are configured by three DIP switches, shown below.

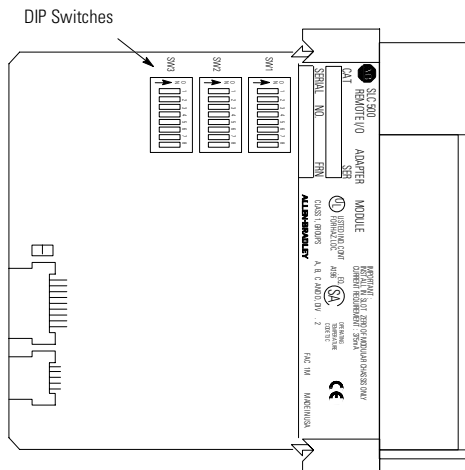

Configuration Parameters

The DIP switches allow you to configure the following items:

- **Starting Logical Rack Number (Logical Rack)** - is the 1747-ASB module's starting logical rack number in the scanner's image.
- **Starting Logical Group Number (Logical Group)** - is the 1747-ASB module's starting logical group number within the scanner's image.
- **Baud Rate (Baud Rate)** - is the 1747-ASB module's RIO link communication rate. The baud rate must be the same for all adapters on the RIO link.
- **Primary/Complementary SLC Chassis (PRI/COMP)** - determines whether the 1747-ASB module appears to the scanner as a primary or complementary chassis.
- **Adapter Image Size (IMAGE SIZE)** - indicates the I/O image size to be reserved for the adapter. It can be any size between 2 and 32 groups in 2 logical group increments.
- **Hold Last State (HLS)** - determines whether the discrete output modules are held in their last state when:
 - RIO link communication with the 1747-ASB module is lost.
 - The scanner inhibits the 1747-ASB module.
 - The scanner sends Reset, Adapter Decide commands to the 1747-ASB module.
- **Processor Restart Lockout (PRL)** - determines whether the 1747-ASB module automatically resumes RIO link communications if communication is lost and then restored.
- **Link Response Time (RESP)** - selects restricted or unrestricted RIO link response time.
- **Last Chassis/PLC-3 Backup (LAST CHA)** - When the 1747-ASB module is used with a PLC-2 or PLC-5, this switch indicates to the scanner that the 1747-ASB module is the last adapter mapped into the 1747-ASB module's highest logical rack. When using a PLC-3 processor, the switch determines whether the 1747-ASB module supports the PLC-3 backup function.
- **Addressing Mode (ADDR MODE)** - determines the 1747-ASB module's remote chassis and remote expansion chassis addressing mode. 2-slot, 1-slot, and 1/2-slot are available.
- **Specialty I/O Mode (SP MODE)** - determines whether the 1747-ASB module discretely maps or block transfer maps specialty I/O modules in its remote chassis and remote expansion chassis.
- **I/O Module Keying (KEY)** - determines if the 1747-ASB module saves its current I/O module and DIP switch configuration to its non-volatile memory, or if the 1747-ASB module compares the current I/O module and DIP switch configuration to the one saved in its non-volatile memory.

Dip Switch Settings

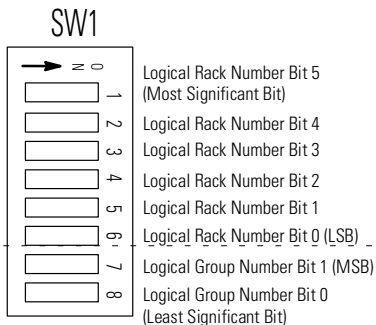

Local Rack Number

ON = 0	OFF = 1
--------	---------

Local Group Number

7	8	Group
ON	ON	0 (default)
ON	OFF	2
OFF	ON	4
OFF	OFF	6

IMPORTANT

The ASB module can be configured as any logical rack number from 0 to 77 octal. Rack numbers are determined by setting switches SW1-1 through SW1-6, with ON equivalent to logical 0 and OFF equivalent to logical 1. Then, interpret this 6-bit binary value as octal with SW1-6 as the least significant bit (LSB). For example:

SW1-1	SW1-2	SW1-3	SW1-4	SW1-5	SW1-6	Rack
ON	OFF	ON	ON	ON	OFF	21 (octal) 17 (decimal)
(0)	(1)	(0)	(0)	(0)	(1)	

SW2

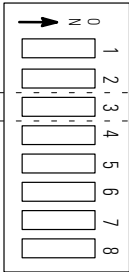

Baud Rate Bit 1 (MSB)

Baud Rate Bit 0 (LSB)

Primary/Complementary Chassis

Reserved

ASB Module Image Size Bit 3 (MSB)

ASB Module Image Size Bit 2

ASB Module Image Size Bit 1

ASB Module Image Size Bit 0

Baud Rate

SW2-1	SW2-2	Baud Rate
ON	ON	57.6K (default)
ON	OFF	115.2K
OFF	ON	230.4K
OFF	OFF	INVALID

Primary/Complementary Chassis

ON	Primary
OFF	Complementary

1747-ASB Module Image Size

5	6	7	8	Groups
ON	ON	ON	ON	2
ON	ON	ON	OFF	4
ON	ON	OFF	ON	6
ON	ON	OFF	OFF	8
ON	OFF	ON	ON	10
ON	OFF	ON	OFF	12
ON	OFF	OFF	ON	14
ON	OFF	OFF	OFF	16
OFF	ON	ON	ON	18
OFF	ON	ON	OFF	20
OFF	ON	OFF	ON	22
OFF	ON	OFF	OFF	24
OFF	OFF	ON	ON	26
OFF	OFF	ON	OFF	28
OFF	OFF	OFF	ON	30
OFF	OFF	OFF	OFF	32

IMPORTANT

If you are not using complementary I/O, you must set SW2-3 to the OFF, or complementary, position.

SW3

0	Hold Last State
1	Processor Restart Lockout
2	Link Response
3	Last Chassis/PLC-3 Backup
4	Addressing Mode Bit 1 (MSB)
5	Addressing Mode Bit 0 (LSB)
6	Specialty I/O Mode
7	I/O Module Keying
8	

Hold Last State

ON	Hold Last State
OFF	Do not Hold Last State (default)

**Processor Restart Lockout
(after lost communications)**

ON	Automatic Restart (default)
OFF	Processor Lockout

Link Response

ON	Restricted (default)
OFF	Unrestricted

Addressing Mode

ON	ON	Invalid
ON	OFF	1-slot Addressing (default)
OFF	ON	1/2-slot Addressing
OFF	OFF	2-slot Addressing

Last Chassis

ON	Not Last Chassis (default)
OFF	Last Chassis

Specialty I/O Mode

ON	Discrete (default)
OFF	Block Transfer

I/O Module Keying

ON	Save Mode (default)
OFF	Check Mode

Installing the Module

ATTENTION

Disconnect power before attempting to install or remove the module.



1. Make sure system power is off.

2. Install the module in slot 0 of the remote chassis by aligning the circuit board with the chassis card guide.

The 1747-ASB module must be installed only in slot 0 (the left slot) of the remote chassis. Do not install the 1747-ASB module in the remote expansion chassis.

3. Slide the module into the chassis until the top and bottom tabs lock into place. To remove the module, press and hold the release located on each self-locking tab and slide the module out.
4. Cover all unused slots with the Card Slot Filler, Catalog Number 1746-N2.

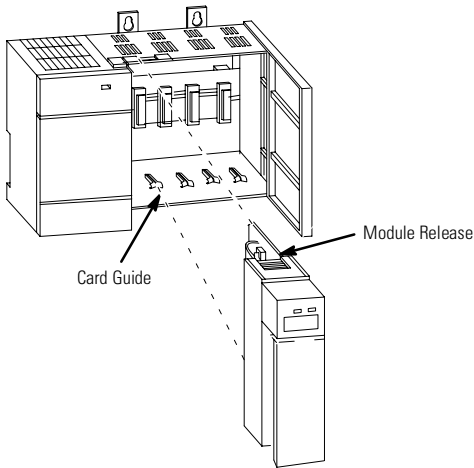

Connecting RIO Link Devices

Link Wiring

The modules are connected in a daisy chain configuration on any RIO link. A daisy chain network is formed by connecting network devices together in a serial manner using Belden 9463 cable. Belden 9463 cable is the only approved cable for Allen-Bradley RIO links.

The total number of adapters allowed on the RIO link is:

- 32 if the scanner and *all* adapters on the RIO link have extended node capability
- 16 if the scanner or any adapter does not have extended node capability

There are no restrictions governing the spacing between the devices, as long as the maximum cable distance is not exceeded. Refer to the table on page 18 for baud rate and maximum cable distances.

IMPORTANT

No two devices can be connected to the same point on the link. An example of correct and incorrect link wiring is shown below.

Correct Link Wiring

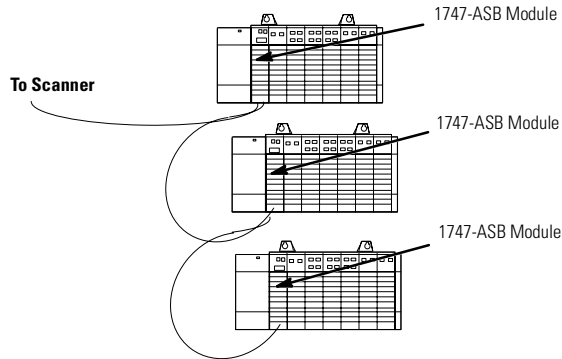

Incorrect Link Wiring

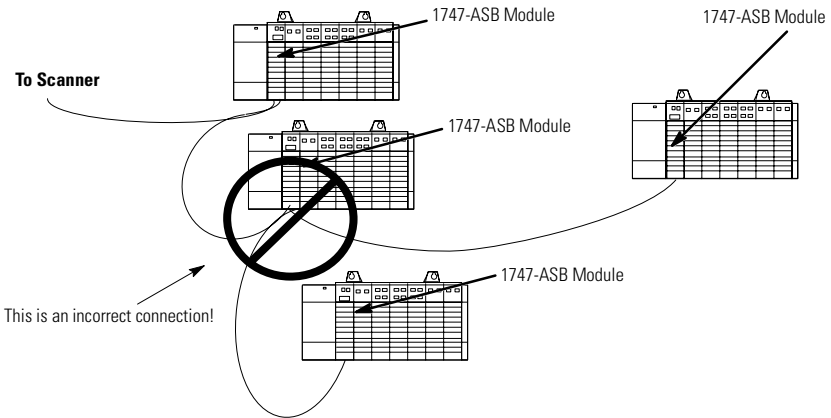

Link Termination

A 6-pin keyed connector provides a quick connection to the RIO link and processor restart lockout switch. A user-supplied terminating resistor must be attached across lines one and two of the connector at each end of the RIO link. The size of the resistor depends on the baud rate and whether the scanner and all adapters have extended node capability, as shown in the table below. The cable shield must be connected to chassis ground *only* at one end of the RIO link.

	Baud Rate	Resistor size
Using Extended Node Capability	All Baud Rates	82Ω 1/2 Watt
	57.6K baud	150Ω 1/2 Watt
Not Using Extended Node Capability	115.2K baud	150Ω 1/2 Watt
	230.4K baud	82Ω 1/2 Watt

IMPORTANT

If the signal integrity on the RIO link is compromised by environmental noise, improper termination, and/or improper cable installation, the 1747-ASB module scan rate drops. This is indicated by a pronounced flickering of the status display.

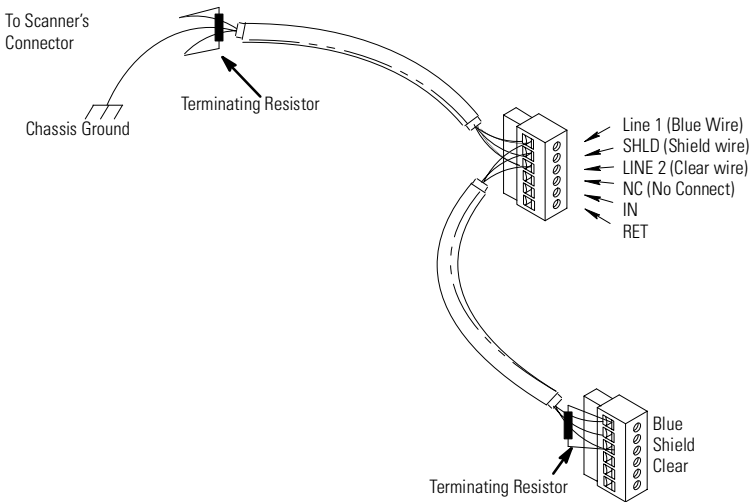

IMPORTANT

Do not connect anything to the NC (No Connect) terminal.

Wiring a Processor Restart Lockout Switch

When processor restart lockout is enabled (SW3-2) and communications are restored, the 1747-ASB module does not respond to any type of communication, or communication commands until terminals IN and RET are momentarily shorted together. This occurs while the RIO scanner is attempting to communicate with the 1747-ASB module.

ATTENTION



Cycling power on any 1747-ASB module chassis removes the processor restart lockout condition by re-initializing the 1747-ASB module.

Use a momentary switch (Class 1, Division 2) to short terminals IN and RET together. The processor restart lockout is removed as soon as the switch toggles back to the open circuit position.

IMPORTANT

Do not connect anything to the NC (No Connect) terminal.

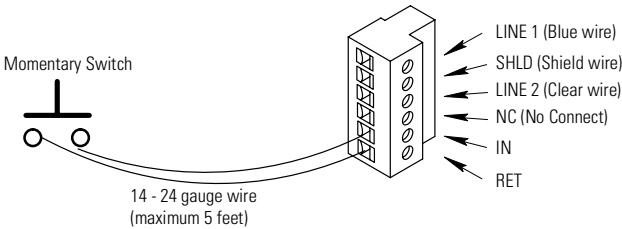

Installing I/O Module Addressing Labels

Attach the Remote PLC or Remote SLC label to the outside bottom of each I/O module in your 1747-ASB chassis, as shown below. Fill out each label completely.

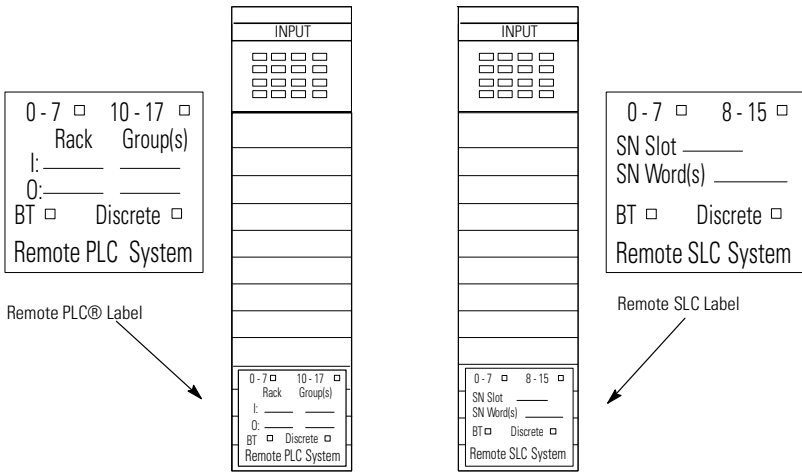

Using a SLC as a Master

If you are using a SLC processor as a master, each I/O module is addressed by the physical slot number of the 1747-SN scanner and the word that the I/O module uses in the scanner image. Data is transferred on the network by logical rack and logical group number. Refer to *Remote I/O Scanner User Manual*, publication number 1747-6.6, for more information on the 1747-SN.

Using a PLC as a Master

If you are using a PLC processor as a master, each I/O module is addressed by logical rack and logical group, regardless of what physical slot it is in. If using a PLC processor as a master, attach octal labels.

Installing Octal Labels

The octal filter and door label kits must be used when working with a PLC processor as a master. Adhere the octal labels over the existing decimal labels, as shown below. Contact your local Allen-Bradley distributor if you need to order additional label kits.

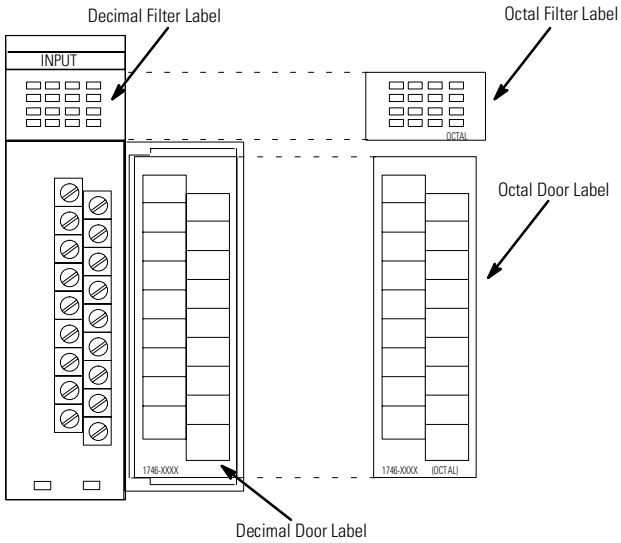

Performing System Start-up

ATTENTION

Never insert, remove, or wire modules with power applied to the chassis or devices wired to the module.



Follow the steps below:

1. Cycle power one last time in save mode (SW3-8 ON).
2. Remove power from the system.
3. Remove the 1747-ASB module and set SW3-8 to the OFF position (check mode).
4. Replace the 1747-ASB module in slot 0.
5. Apply power to your system.

Checking Operation

During normal operation (PLC or SLC in Run mode), the 1747-ASB module appears as shown below.

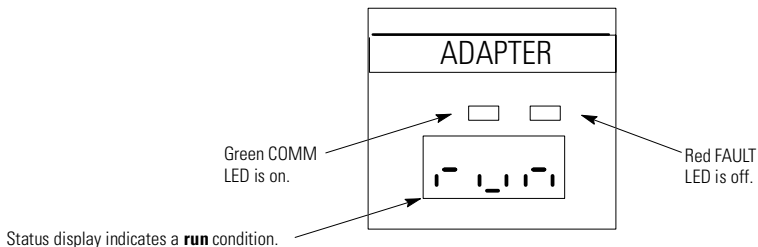

Specifications

Adapter Operating Specifications

Backplane Current Consumption	375 mA at 5V dc
Operating Temperature	32°F to 140°F (0°C to 60°C)
Storage Temperature	-40°F to +185°F (-40°C to +85°C)
Humidity	5% to 95% non-condensing
Noise Immunity	NEMA standard ICS 2-230
Vibration	Displacement: 0.015 inch, peak-to-peak at 5-57 Hz Acceleration: 2.5Gs at 57-2000 Hz
Shock (operating)	30Gs
Agency Certification (when product or packaging is marked)	<ul style="list-style-type: none"> • UL Listed • CSA certified • Class I, Division 2 Groups A, B, C, D • CE compliant for all applicable directives • Marine Certified • C-tick marked for all applicable acts

Baud Rate Determination of Maximum Cable Length and Terminating Resistor Size

	Baud Rate	Maximum Cable Distance (Belden 9463)	Resistor Size
Using Extended Node Capability	57.6K baud	3048 meters (10,000 feet)	82Ω 1/2 Watt
	115.2K baud	1524 meters (5,000 feet)	
	230.4K baud	762 meters (2,500 feet)	
Not Using Extended Node Capability	57.6K baud	3048 meters (10,000 feet)	150Ω 1/2 Watt
	115.2K baud	1524 meters (5,000 feet)	
	230.4K baud	762 meters (2,500 feet)	82Ω 1/2 Watt

For More Information

For	Refer to this Document	Pub. No.
A more detailed description on how to install and use your Remote I/O Adapter Module.	Remote I/O Adapter Module User Manual	1747-6.13
A more detailed description on how to install and use your Remote I/O Scanner Module (1747-SN).	Remote I/O Scanner Module User Manual	1747-6.6
A more detailed description on how to install and use your SLC 500™ Modular Hardware Style Control System.	SLC 500™ Modular Hardware Style User Manual	1747-UM011
A more detailed description on how to install and use your SLC 500™ Fixed Hardware Style Control System.	SLC 500™ Fixed Hardware Style Installation and Operation Manual	1747-6.21

If you would like a manual, you can:

- download a free electronic version from the internet:
www.theautomationbookstore.com
- purchase a printed manual by:
 - contacting your local distributor or Rockwell Automation representative
 - visiting **www.theautomationbookstore.com** and placing your order
 - calling **1.800.963.9548** (USA/Canada) or **001.330.725.1574** (Outside USA/Canada)

Rockwell Automation Support

Rockwell Automation provides technical information on the Web to assist you in using its products. At <http://support.rockwellautomation.com>, you can find technical manuals, a knowledge base of FAQs, technical and application notes, sample code and links to software service packs, and a MySupport feature that you can customize to make the best use of these tools.

For an additional level of technical phone support for installation, configuration, and troubleshooting, we offer TechConnect Support programs. For more information, contact your local distributor or Rockwell Automation representative, or visit <http://support.rockwellautomation.com>.

Installation Assistance

If you experience a problem with a hardware module within the first 24 hours of installation, please review the information that's contained in this manual. You can also contact a special Customer Support number for initial help in getting your module up and running.

United States	1.440.646.3223 Monday – Friday, 8am – 5pm EST
Outside United States	Please contact your local Rockwell Automation representative for any technical support issues.

New Product Satisfaction Return

Rockwell tests all of its products to ensure that they are fully operational when shipped from the manufacturing facility. However, if your product is not functioning, it may need to be returned.

United States	Contact your distributor. You must provide a Customer Support case number (see phone number above to obtain one) to your distributor in order to complete the return process.
Outside United States	Please contact your local Rockwell Automation representative for return procedure.

Rockwell Automation, Allen-Bradley, SLC 500, PLC, and TechConnect are trademarks of Rockwell Automation, Inc.

Trademarks not belonging to Rockwell Automation are property of their respective companies.

www.rockwellautomation.com

Power, Control and Information Solutions Headquarters

Americas: Rockwell Automation, 1201 South Second Street, Milwaukee, WI 53204-2496 USA, Tel: (1) 414.382.2000, Fax: (1) 414.382.4444

Europe/Middle East/Africa: Rockwell Automation, Vorstlaan/Boulevard du Souverain 36, 1170 Brussels, Belgium, Tel: (32) 2 663 0600, Fax: (32) 2 663 0640

Asia Pacific: Rockwell Automation, Level 14, Core F, Cyberport 3, 100 Cyberport Road, Hong Kong, Tel: (852) 2887 4788, Fax: (852) 2508 1846

Publication 1747-IN014C-EN-P - January 2003

PN 40071-134-01(3)

Supersedes Publication 1747-IN014B-EN-P - May 2001

Copyright © 2007 Rockwell Automation, Inc. All rights reserved. Printed in Singapore.