



## KNOWLEDGE BASE

Article Type: **Instructions**

### **Remote Temperature Controller for Heated Mold Shoes, using a RTD/Digital Display, #601127.D (version 2009 +).**

#### Description:

Instructions on “How to” properly set-up and operate Remote Temperature Controller using a RTD/Digital Display; part # 601127.D.

Three (3) control circuits – 230 volt/each up to 20 amps (4KW),  
Total (12KW), single phase.

Typically used on Models 22HF, and 16HF machines, and (2 and 3) block Pit Model machines.

This controller version implemented and shipped after February 2009.

#### **WARNING**

Never work on, clean or service this unit, control panel or any machine or open or remove any protective cover, guard, grate, door, or maintenance panel until the power or energy sources has been turned off, locked out / tagged out, and all moving parts have come to a complete stop and or blocked to prevent movement. Machinery is dangerous - avoid personal injury and or death by following manufacture, Local, and OHSА safety procedures. Contact Columbia Machine for safety decals, guards, horns and beacons.



# Remote Temperature Controller with RTD/Digital Display for Heated Mold Shoes 601127.D

Columbia Machine, Inc.  
Vancouver, Washington

This manual provides installation and operation information applicable to the Columbia Remote Temperature Controller for Heated Mold Shoes.

## TABLE OF CONTENTS

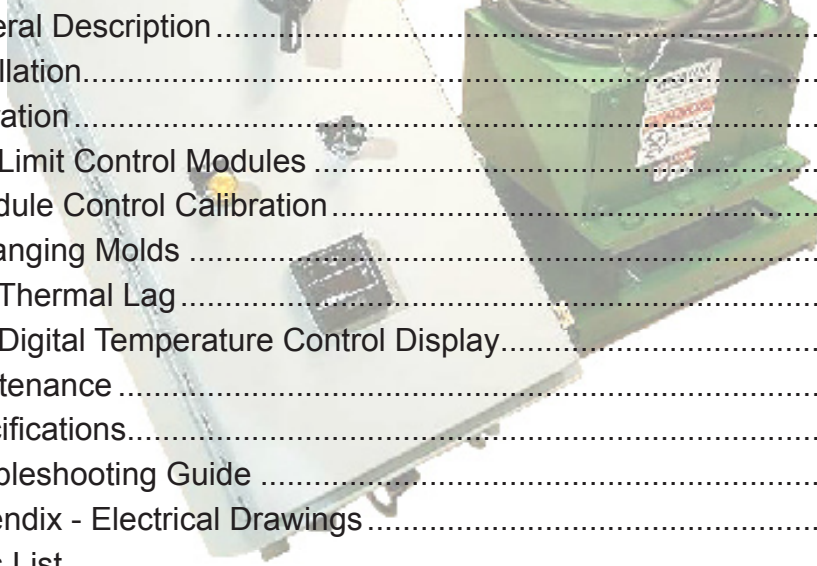

General Description .....	2
Installation.....	4
Operation .....	6
• Limit Control Modules .....	7
• Module Control Calibration.....	8
• Changing Molds .....	8
• Thermal Lag .....	8
• Digital Temperature Control Display.....	9
Maintenance .....	10
Specifications.....	10
Troubleshooting Guide .....	11
Appendix - Electrical Drawings.....	12
Parts List.....	16

# Columbia Concrete Products - Remote Temperature Controller

## General Description



The Columbia remote temperature controller part #601127.D is designed to heat the mold shoes. Heating the mold assembly shoes prevents block material from adhering to mold shoe surfaces as block is formed in the production process. The remote temperature controller regulates the temperature of the mold shoes using temperature feedback and RTD devices.

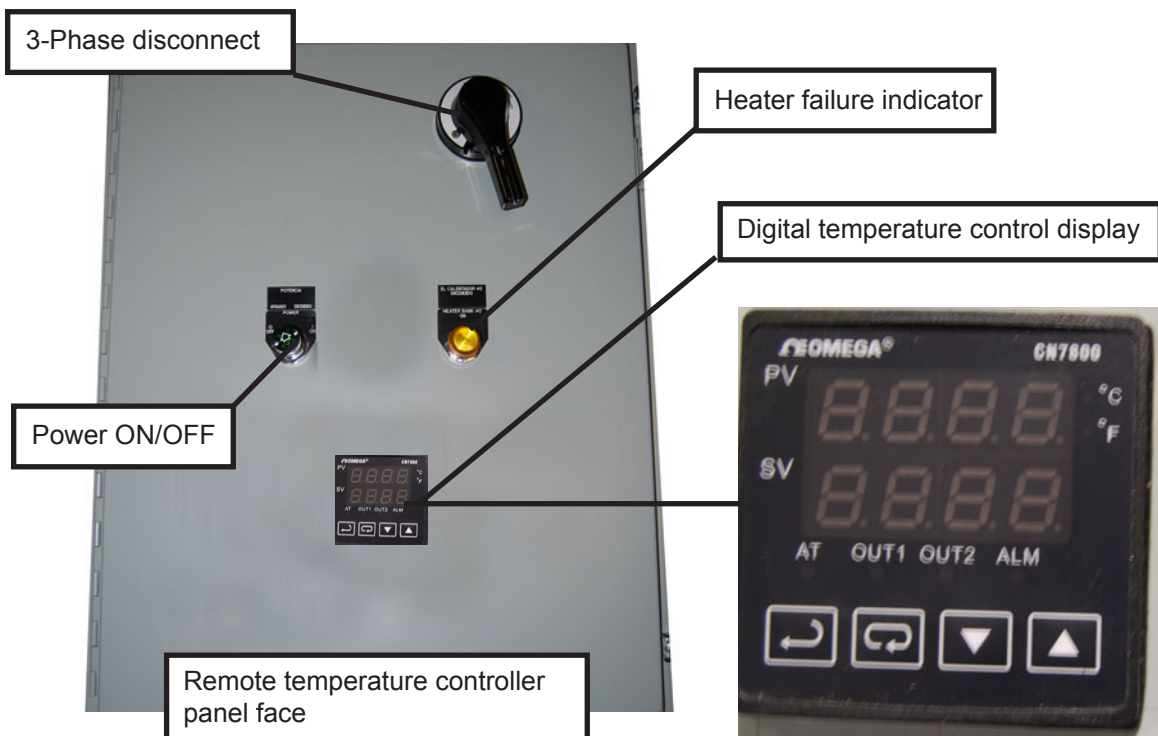

## Columbia Concrete Products - Remote Temperature Controller

The remote temperature controller uses two power cables. One cable connects the heated mold shoes to the control panel which supplies the necessary power to heat the mold shoes. A second cable connects the RTD to the control panel box, and supplies power to the temperature feed-back device. The heater control panel face consists of a 3-phase disconnect switch, power on/off switch, a heater failure indicator light, and a digital temperature controller display. The inside of the control panel box contains the circuit breakers, contactors, limit alarm module, current transformer (CT) necessary to operate the remote temperature controller.

The heater control panel can control three (3) 230 volt circuits, each up to twenty (20) ampere, for a total of 12KW single phase. When power is applied, a resistance temperature detector (RTD), located inside the heated shoe, indicates the current temperature sensed by the RTD. Operators can change the “set-point temperature” by pushing the up/down arrow keys (located on the digital controller). The set-point temperature is the temperature operators should maintain during production. Current temperature is top line on display, the lower line is the set-point display.

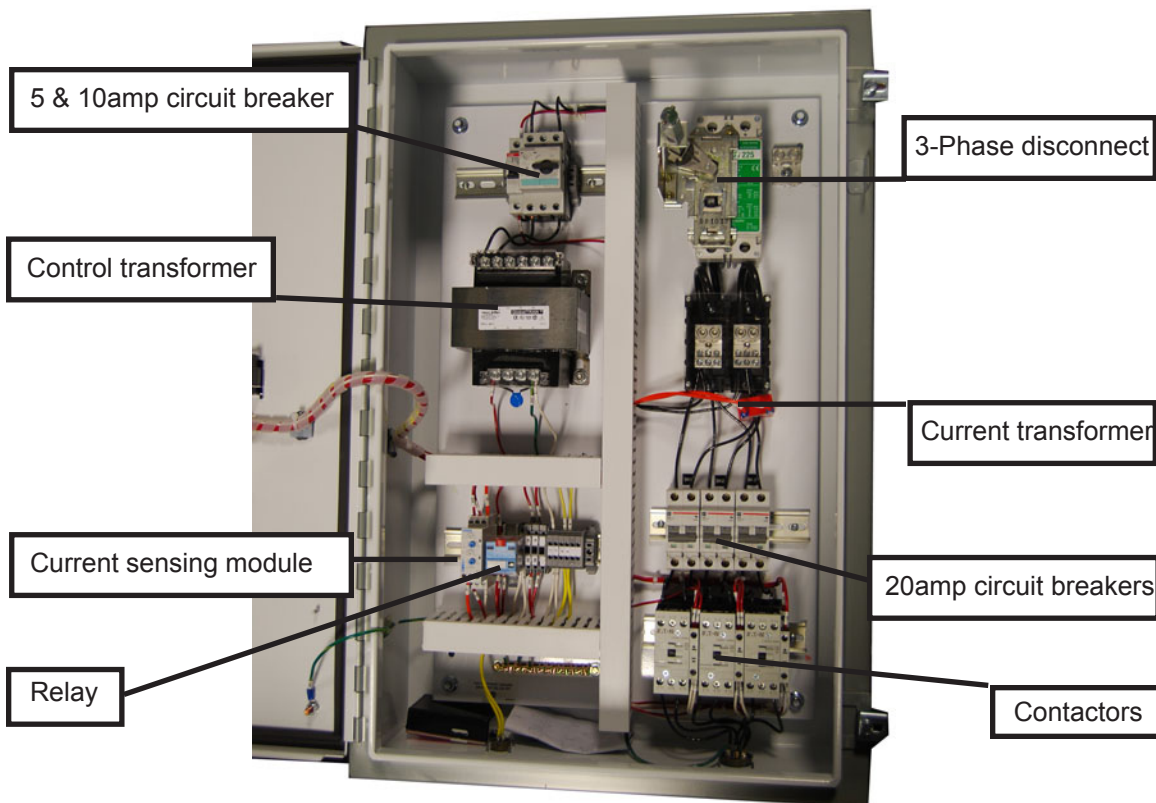

The 601127.D heater control unit controls up to (12KW) 60 amps, divided into three (3), (4KW) circuits, at 230 volts, single (1) phase.

## Columbia Concrete Products - Remote Temperature Controller

---

As areas of high temperature on the mold shoes come into contact with areas of low temperature in the mix material, temperature differences between the concrete mix and heated mold assembly shoes can approach 100° F. This is a normal occurrence, and the temperature will continue to rise and fall during operation as new material enters the mold, makes contact with the mold shoes, and then exits the mold.

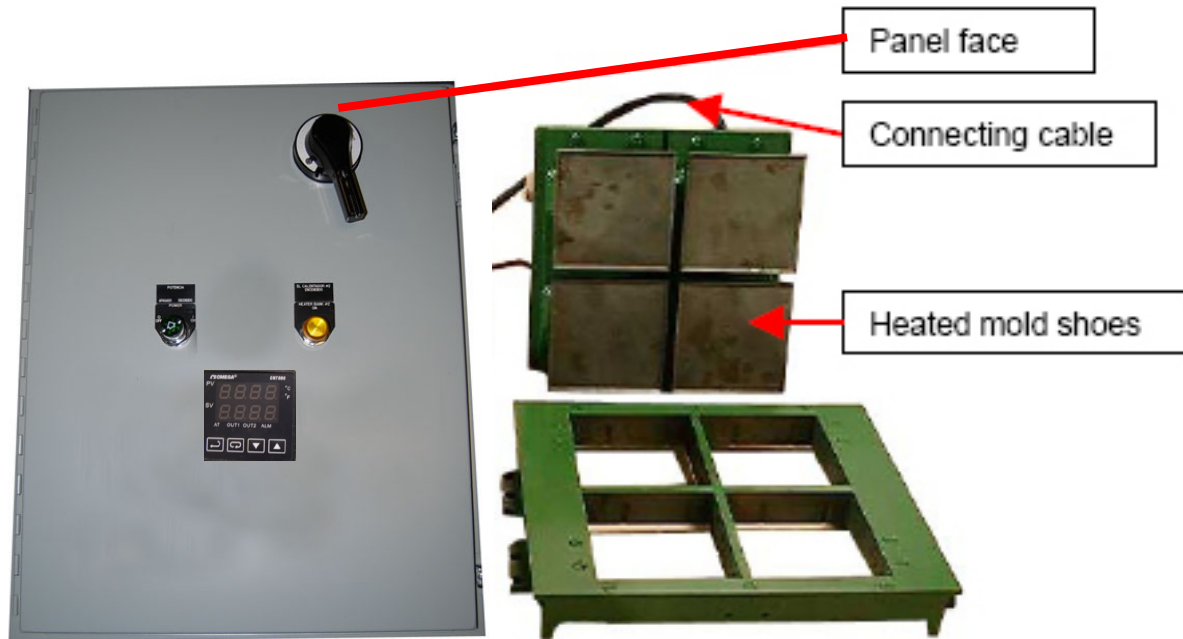

# Columbia Concrete Products - Remote Temperature Controller

---

## Installation

To install the Heated Mold Assembly and Mold Shoe Heater Control Panel, perform the following steps:

1. Remove the components from the crates
2. Inspect for damage
3. Ensure that all of the following items are included in shipment:
  - a. Heated mold shoe control panel & box
  - b. One magnetic thermometer
  - c. One set of electrical drawings



4. Mount the control panel box on a wall:
  - a. In an area free from high vibration
  - b. At a distance where the cables can reach the mold assembly
5. Install and connect the control power
  - a. Install a conduit for control power
  - b. Connect 240 vac/ 60 amp single phase control circuit to the panel
6. Connect the control power cable and RTD cable from the heated mold to the panel:
  - a. Locate the cables away from any moving parts
  - b. Ensure that the cables have a flexible range of motion
7. Switch on power for operation

# Columbia Concrete Products - Remote Temperature Controller

---

## Operation

A typical remote temperature controller system contains:

- Heat sensor (RTD)
- Digital temperature controller (CN7833)
- Current sensing module
- Process load (heated mold shoes)

As the temperature of the heated shoes increases, the controller compares the set-point temperature with the temperature indicated by the RTD sensor. If the temperature sensed by the RTD falls below the set-point, the controller applies power to the contactor until the temperature, which is indicated by the LED indicator on the panel face, reaches the set-point. The set-point (target) temperature is indicated reading the lower display.

The remote temperature controller uses 600 watts of electric current per heater to generate heat inside the shoe. If the shoes experience a drop in current which leads to a drop in temperature below the set-point threshold or limit, the current sensing module and current monitor (CT) signals the yellow indicator light to illuminate.



The indicator light will illuminate during failure only if the limit alarm is energized and the shoes are powered.



The indicator light may give a false signal when the controller initially energizes.

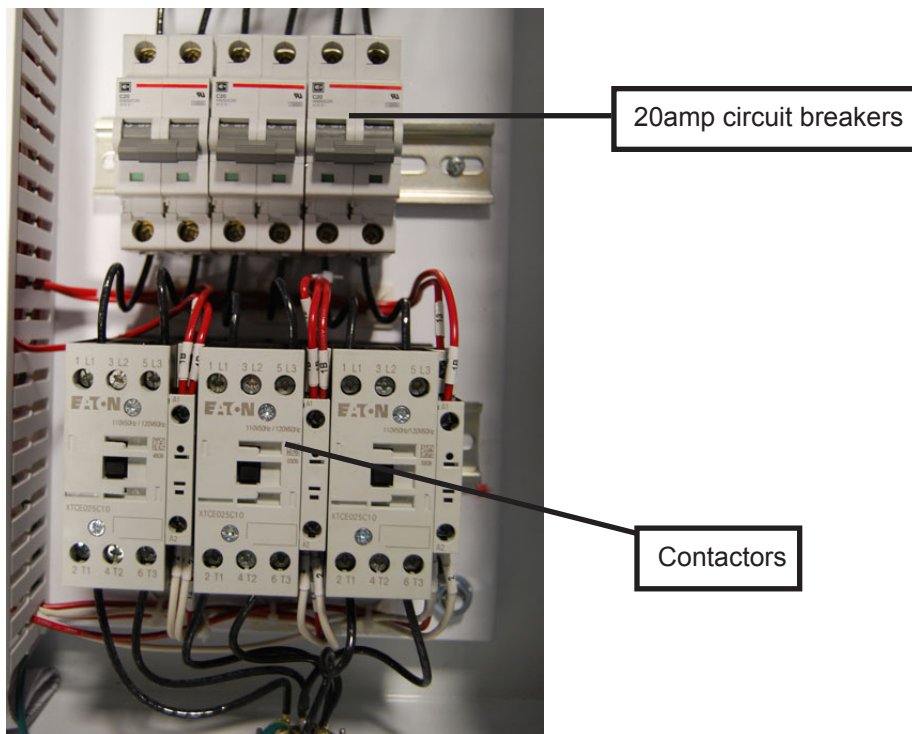

## Current Sensing Module

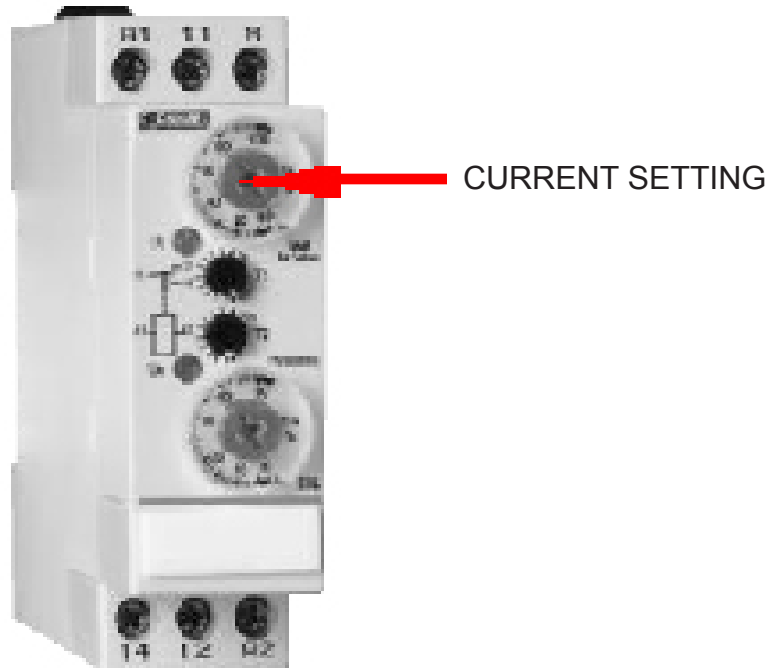

The current sensing module detects a heater failure when the current drawn by the heater falls below the normal range.

## Module Calibration

To calibrate the module use a Known Good Heater Element

1. Have all heater circuit breakers on
2. Energize the contactor
3. The Molder Heater Power on Indicating light on the front of the panel should be on
4. Turn one Mold Heater circuit breaker off
5. The light should go out
6. If the light does not go out, adjust the current setting on the module until it just turns off
7. When you reclose the circuit breaker the light should turn back on.
8. This sets the under current set-point for the module



## Changing Molds

Each mold requires a unique amount of wattage to sufficiently heat the shows. When changing molds, re-calibrate the module in order to detect a heater failure accurately. Record the appropriate set point for each mold for quick reference when changing molds

## Thermal Lag

Thermal lag occurs as areas of high temperature on the mold shoes come into contact with areas of low temperature in the mix material, and temperature differences between the concrete mix and heated mold assembly shoes approach 100° F. This is a normal occurrence, and the temperature will continue to rise and fall during operation as new material enters the mold, makes contact with the mold shoes, and then exits the mold.

Thermal lag also occurs when the shoes reach the set-point temperature, yet slowly continues to increase in temperature, as indicated by the digital temperature controller. The temperature continues to increase because heat continues to migrate from the heaters in spite of termination of power.



Operate the heated mold within the recommended operating temperature of 150°- 200°. Never exceed a temperature of 350°.

## Digital Temperature Control Display



1. The actual temperature as read by the RTD is displayed as the top number on the display
2. The desired temperature is displayed on the second line of the display
3. Use the Up arrow and down arrow buttons to increase or decrease the desired setpoint
4. An output LED indicator illuminates when the the output circuitry is actuated

# Columbia Concrete Products - Remote Temperature Controller

## Maintenance

Item	Frequency	Procedure
Digital temperature controller	Prior to use	Clean and protect from dirt, oil, corrosion, and vibration
Mold head-box	Prior to use	Tighten connections
Control panel	Monthly	Inspect connections for positive contact
Digital temperature controller Electrical connections	Monthly	Inspect connections
Power cables/RTD cables	As needed	Replace when frayed or damaged



### CAUTION

Do not clean the front panel bezel and the meter face with solvent. Doing so will damage the plastic surface.

## Specifications

Component	Specifications
Panel box	20" wide x 30" high x 8" deep
Input voltage	220 AC – single phase
Output circuit current	3 – 20 amp circuits, 4 kw/circuit
Main breaker	60 amp, 12 kw total

# Columbia Concrete Products - Remote Temperature Controller

## Troubleshooting

Symptom	Probable Cause	Check	Corrective Action
Mold shoes not heating	No line voltage	Verify 240 VAC voltage	Restore power
	Open main breaker	Check main breaker	Close main breaker
	Open main circuit	Check heater for shorting	Close circuit breaker
	Power cable	Check cable for cuts, damage, or tears; Check connector & plug	Replace cable; tighten or replace connector & plug
	Terminal connections	Check terminal connections inside mold head	Tighten terminals
	Failed heater	Check heater for open circuit	Replace heater
	Contactors not energized	Check 120 VAC voltage Check digital display settings	Close 120 VAC circuit breaker set preset temperature
Digital temperature controller is inactive. No output light or digital display.	No line voltage	Check fuse Check power on/off selector switch Check circuit breaker	Replace fuse Turn switch on
Digital temperature controller reads ambient temperature	Defective heater	Heater	Replace heater
	Open heater	Heater	Replace heater
	Defective power cable	Power cable	Replace power cable
Output light not illuminated on digital temperature controller	Open RTD	RTD	Replace RTD
	Defective RTD cable	Check cable for cuts, damage, or tears Check connector and plug	Replace cable Tighten or replace connector and plug
Digital temperature controller display reads negative numbers	RTD	Check cable for proper wiring	Correct wiring
Heater failure indicator light "on"	Calibrate/setup	See calibration section of manual	Recalibrate
	Defective heater	Heater	Replace heater

# Columbia Concrete Products - Remote Temperature Controller

## Appendix: Electrical Drawings

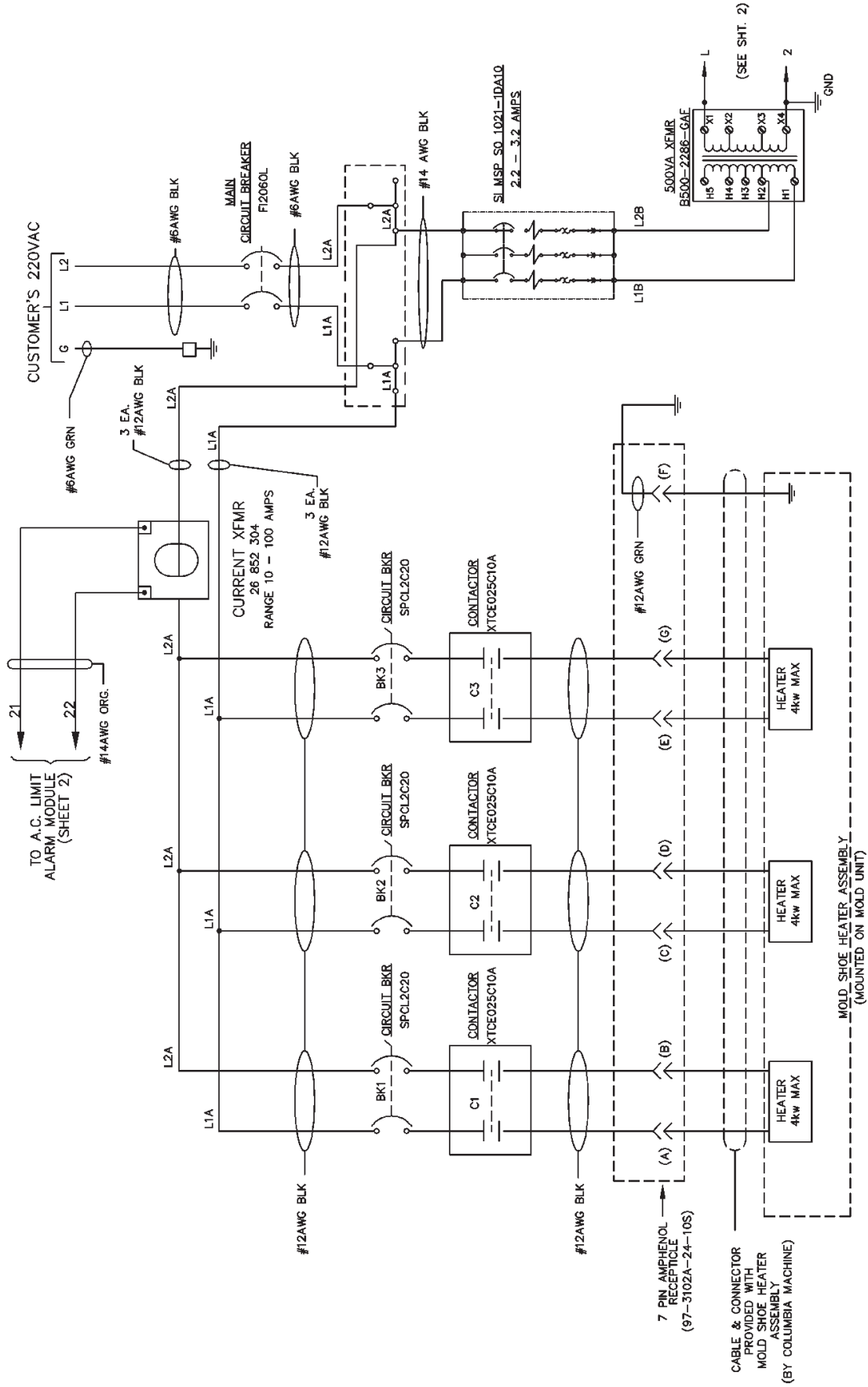

# Columbia Concrete Products - Remote Temperature Controller

## Appendix: Electrical Drawings

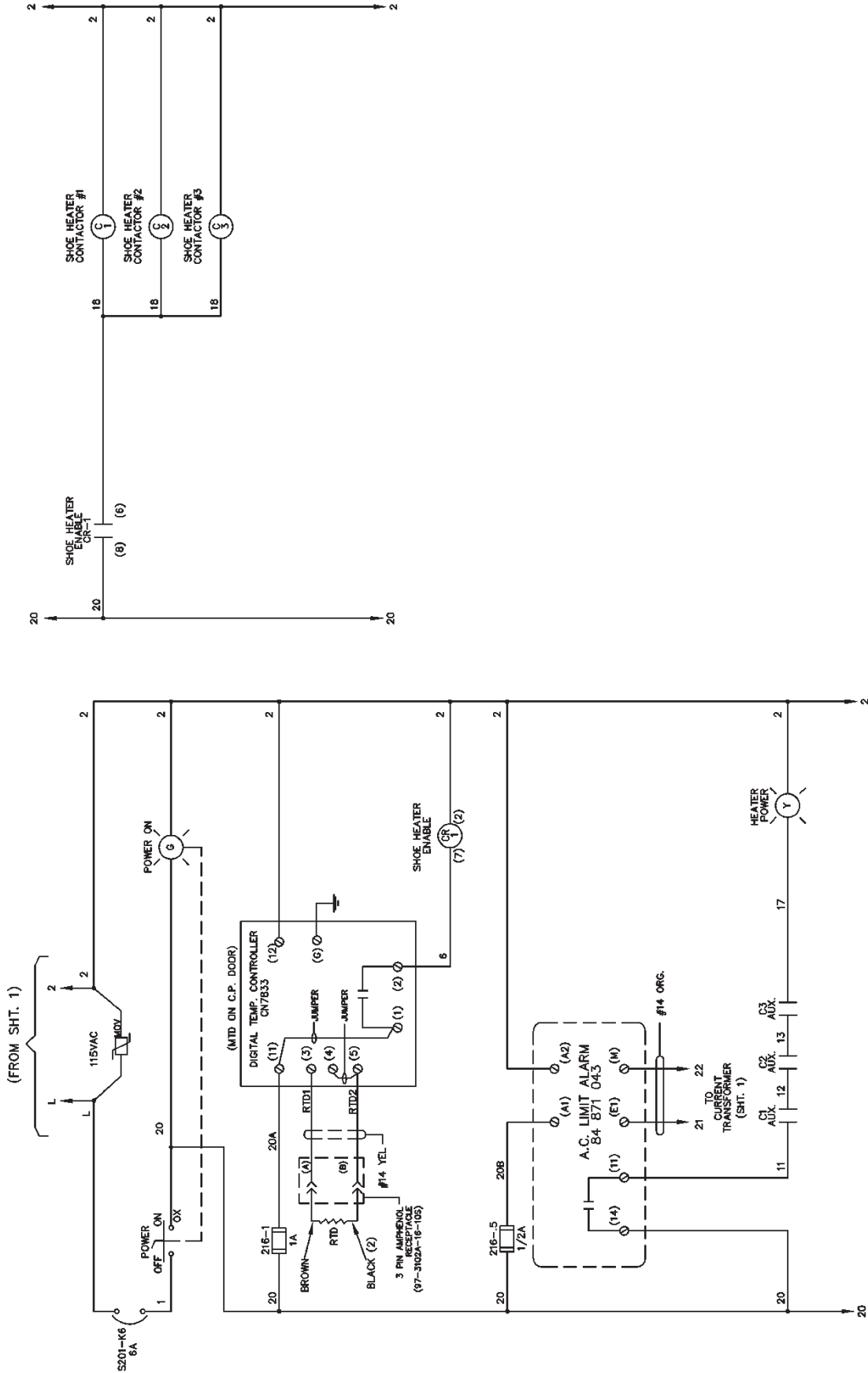

# Columbia Concrete Products - Remote Temperature Controller

## Appendix: Electrical Drawings

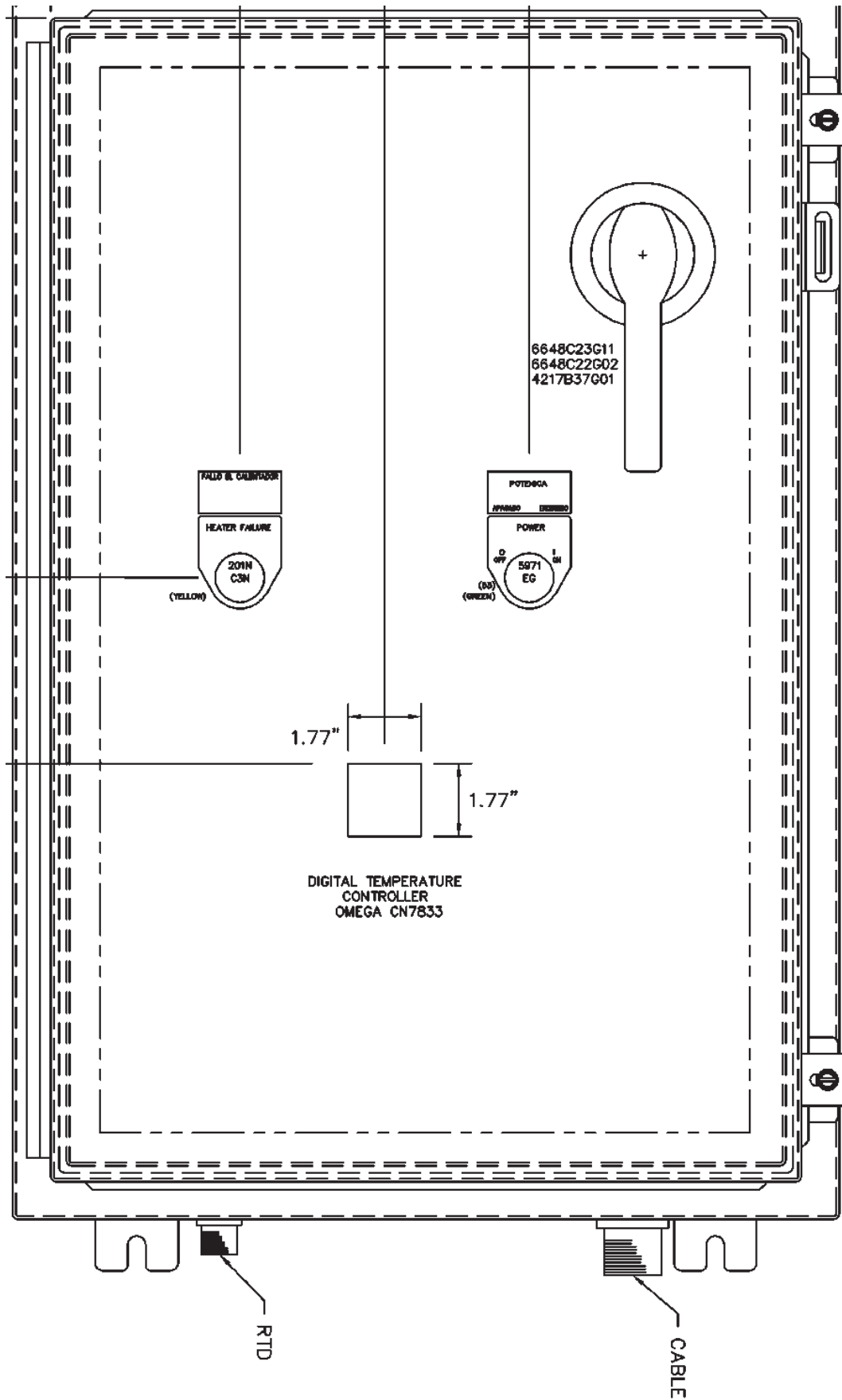

# Columbia Concrete Products - Remote Temperature Controller

Appendix: Electrical Drawings

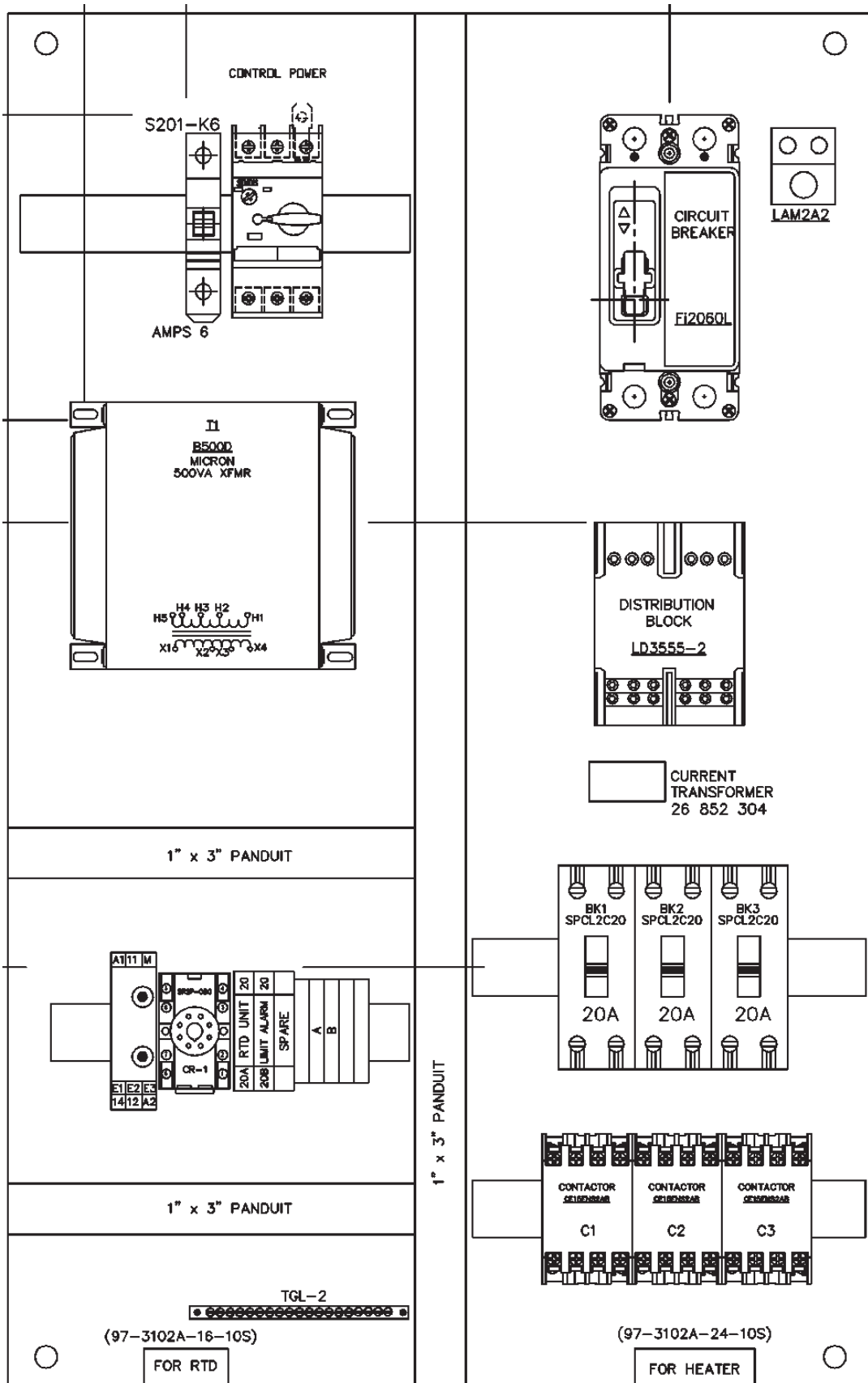



## Columbia Concrete Products - Remote Temperature Controller

---

### Parts List

<u>No.</u>	<u>Description</u>	<u>Columbia Part Number</u>	<u>No. Req'd.</u>
1	Encl,30X20X8,A-302008Lp	2015222	1
2	Panel F/27X17 Nema,A-30P20	2015276	1
3	Dist Block Pwr,334A,Ld3555-2	2010549	1
4	Breaker 2Pole 20A Ce, Spcl2C20	2014469	3
5	Breaker 2Pole 60A Ce, Fi2060L	2014470	1
6	Si Msp S0, 2.2-3.2 1021-1Da10	2001178	1
7	Breaker 1Pole 6A, S201-K6	2012609	1
8	Breaker Frame F,6648C23G11	2014332	1
9	Breaker Frame F,6648C22G02	2014103	1
10	Breaker Shaft 12,4217B37G01	2014329	1
11	Current Cntrl Relay 10-100 Amp	2367991	1
12	Current Xformer 10-100Amp	2367992	1
14	Receptacle, Socket, 7 Pin	232809	1
15	Connector Box 97-3102A-16-10S	2010792	1
16	Cap For Receptacles,9760-24	232811	1
17	Cap For Receptacles,9760-16	232834	1
18	Thermometer,314F	234325	1
19	Trnsfmr, B500-2286-Gaf	2017002	1
20	Op Selector,10250T5971, 120Vac	201841	1
21	Contact Blk,1No,10250T53	200197	1
22	Unit,Basic Light,10250T201N	200071	1
23	Lens, 10250Tc3N, Yellow	201913	1
24	Op Knob,Grn,10250Teg	200121	1
25	Controller,Temp,Omega,Cn7833	2367990	1
26	Contact Blk Shroud,10250Ta101	201949	4
27	Contact, lec 2P 25	2012698	3
28	Relay Dpdt C2A20X-120Vac	236831	1
29	Relay Base 8 Pin,Sr2P-05C	236979	1
32	Fuse,Gda 1 Amp	202725.001.000	2
33	Fuse,Gda 500Ma	202725.000.500	2
34	Trmnl Blk,M4/6,#10,115.116.07	201580	5
35	Trmnl,End Cover,Std,118.368.16	201582	1
36	Clamp,End,Entrelec,103.002.26	201583	2
37	Trmnl Fuse,8Mm,115-657.25	203656	3
38	Trmnl End Cover 8Mm,116-951.15	203657	1
39	Trmnl Gnd,Lam2A2/0-14-6	2010185	1
40	Grounding Kit,Tgl-2	231110	1