



KNOWLEDGE BASE

Article Type: **Instructions**

Remote Temperature Controller for Heated Mold Shoes, using a Timer, #601126.C (version 2009 +).

Description:

Instructions on “How to” properly set-up and operate Remote Temperature Controller using a Timer; part # 601126.C.

Three (3) control circuits – 230 volt/each up to 20 amps (4KW),
Total (12KW), single phase.

Typically used on Models 22HF, and 16HF machines, and (2 and 3) block Pit Model machines.

This controller version implemented and shipped after February 2009.

WARNING

Never work on, clean or service this unit, control panel or any machine or open or remove any protective cover, guard, grate, door, or maintenance panel until the power or energy sources has been turned off, locked out / tagged out, and all moving parts have come to a complete stop and or blocked to prevent movement. Machinery is dangerous - avoid personal injury and or death by following manufacture, Local, and OSHA safety procedures. Contact Columbia Machine for safety decals, guards, horns and beacons.



Remote Temperature Controller with Timer for Heated Mold Shoes 601126.C

Columbia Machine, Inc.
Vancouver, Washington

This manual provides installation and operation information applicable to the Columbia Remote Temperature Controller for Heated Mold Shoes.

TABLE OF CONTENTS

General Description	2
Installation.....	4
Operation	5
Specifications.....	6
Troubleshooting	6
Appendix - Electrical Drawings	7
Parts List.....	11

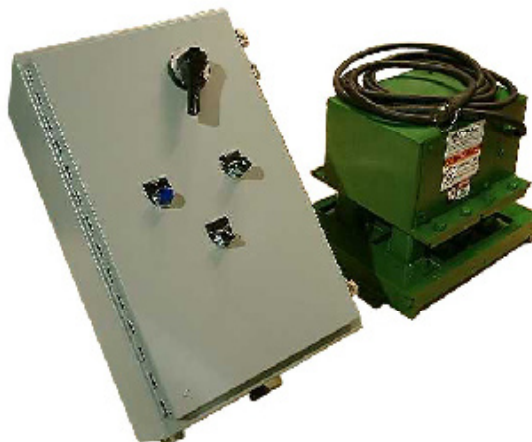

GENERAL DESCRIPTION



The Columbia remote temperature controller part #601126.C is designed to heat the mold shoes. Heating the mold assembly shoes prevents block material from adhering to mold shoe surfaces as block is formed in the production process. The remote temperature controller is an economical alternative that regulates the temperature of the mold shoes using a timer delay switch, without a thermostatic controller or temperature feedback.

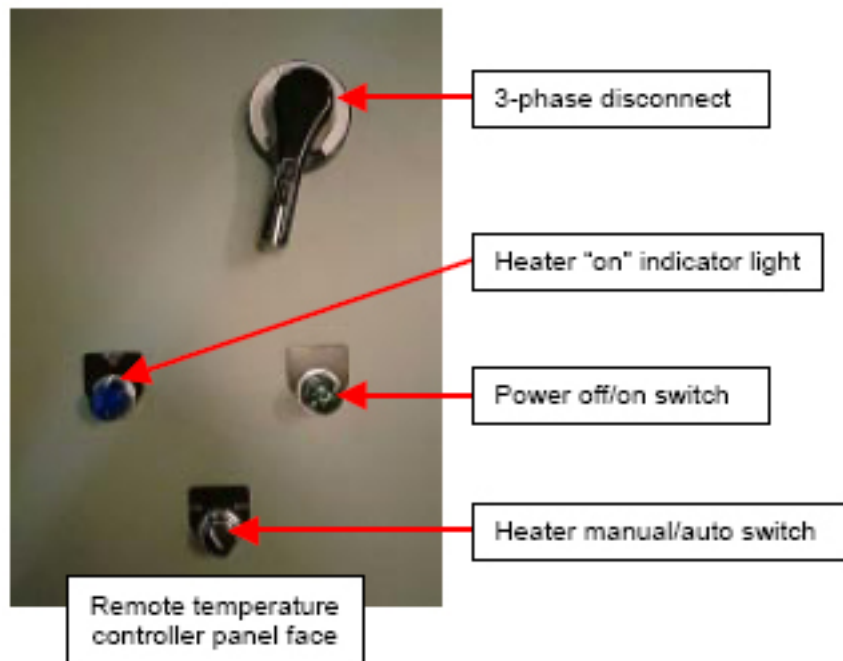

A cable that connects the heated mold shoes to the control panel supplies the necessary power to heat the mold shoes. The heater control panel face consists of a 3-phase disconnect switch, power on/off switch, manual/automatic switch, and a "heater on" indicator light. The inside of the control panel box contains the circuit breakers, contactors, and timing relays necessary to operate the remote temperature controller.

Columbia Concrete Products - Remote Temperature Controller

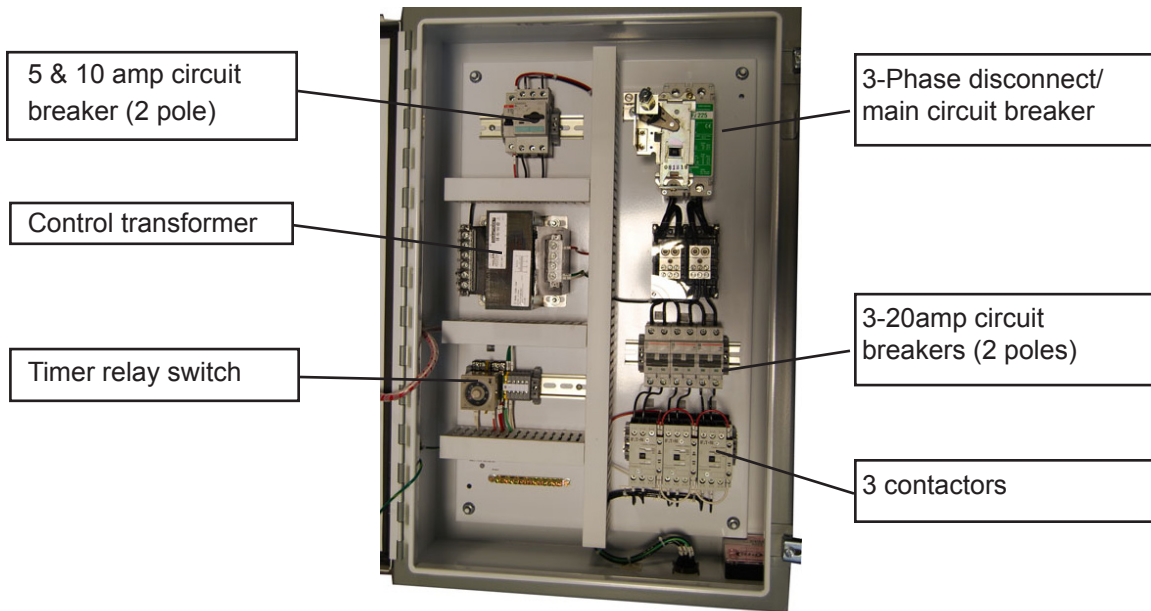

The 601126.C heater control unit controls up to (12KW) 60 amps, divided into three (3), (4KW) circuits, at 230 volts, single (1) phase.

As areas of high temperature on the mold shoes come into contact with areas of low temperature in the mix material, temperature differences between the concrete mix and heated mold assembly shoes can approach 100 ° F. This is a normal occurrence, and the temperature will continue to rise and fall during operation as new material enters the mold, makes contact with the mold shoes, and then exits the mold.



Temperatures will exceed recommended operating levels as the block machine idles while not in production. Avoid damaging the heated mold by turning the remote temperature controller off when the block machine is idling or not in production.

INSTALLATION

To install the Heated Mold Assembly and Mold Shoe Heater Control Panel, perform the following steps:

1. Remove the components from the crates
2. Inspect for damage
3. Ensure that all of the following items are included in shipment:
 - a. Heated mold shoe control panel & box
 - b. One magnetic thermometer
 - c. One set of electrical drawings



4. Mount the control panel box on a wall:
 - a. In an area free from high vibration
 - b. At a distance where the cables can reach the mold assembly
5. Install and connect the control power:
 - a. Install a conduit for control power
 - b. Connect 240vac/60amp single phase control circuit to the panel
6. Connect the control power cable from the heated mold to the panel:
 - a. Locate the cable away from any moving parts
 - b. Ensure that the cable has a flexible range of motion
7. Switch on power for operation

Columbia Concrete Products - Remote Temperature Controller

OPERATION

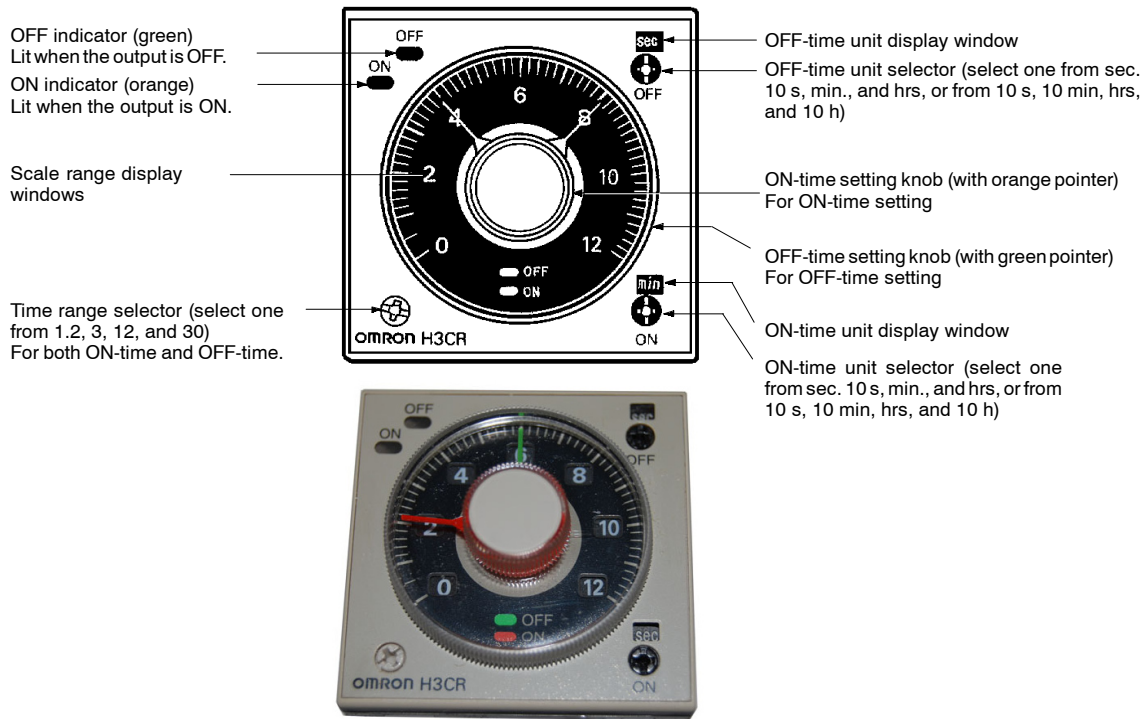

Block machine operators may operate the temperature controller in manual or automatic mode. To operate in the manual mode, operators:

1. Turn the 3-phase disconnect and the power on/off switch to the “on” position
2. Turn the heater manual/auto switch to the manual position
3. The heater “on” indicator light should illuminate

In the manual mode, the remote temperature controller will continue to supply power to heat the mold shoes, until the operator turns the power on/off switch to the “off” position. To operate in the automatic mode, block machine operators must determine the controller temperature by setting the timer delay. The timer delay regulates the length of time that power to the heater coils is turned on and off per cycle. To set the correct temperature for the heater shoes:

1. The Timer is calibrated in seconds. Set the timer dials (off and on) for the time you wish the heater to cycle on and off.
2. Continue to adjust the timer delay “on” dial to higher settings until the block mix no longer adheres to the heated shoes.



Operate the heated mold within the recommended operating temperature of 150°- 200°. Never exceed a temperature of 350°.

3. Other “on” and “off” dial combinations are possible that will suit your plant needs. Use trial and error to achieve alternate setting combinations, if desired.

In the automatic mode, the remote temperature controller will continue to power on and off, as designated by the timer delay settings, until the operator turns the power on/off switch to the “off” position.

Columbia Concrete Products - Remote Temperature Controller

SPECIFICATIONS

<u>Component:</u>	<u>Specifications:</u>
Panel Box	20" wide x 30" high x 8" deep
Input Voltage	220AC - Single Phase
Output Circuit Current	3-20amp Circuits, 4kw/circuit
Main Breaker	60amp, 12kw Total

TROUBLESHOOTING

Symptom:	Probable Cause:	Check:	Action:
Mold Shoes not heating	No line voltage	Verify 240 VAC Voltage	Restore Power
	Open main breaker	Check main breaker	Close main breaker
	Open main circuit	Check heater for shorting	Close circuit breaker
	Power cable	Check cable for cuts, damage, or tears; Check connector & plug	Replace cable; Tighten or replace connector & plug
	Terminal connections	Check terminal connections inside mold head	Tighten terminals
	Failed heater	Check heater for open circuit	Replace heater
	Contactors not energized	Check 120VAC voltage; Check timer relay settings	Close 120 VAC circuit breaker; Adjust "on" & "off" delay time

Appendix: Electrical Drawings

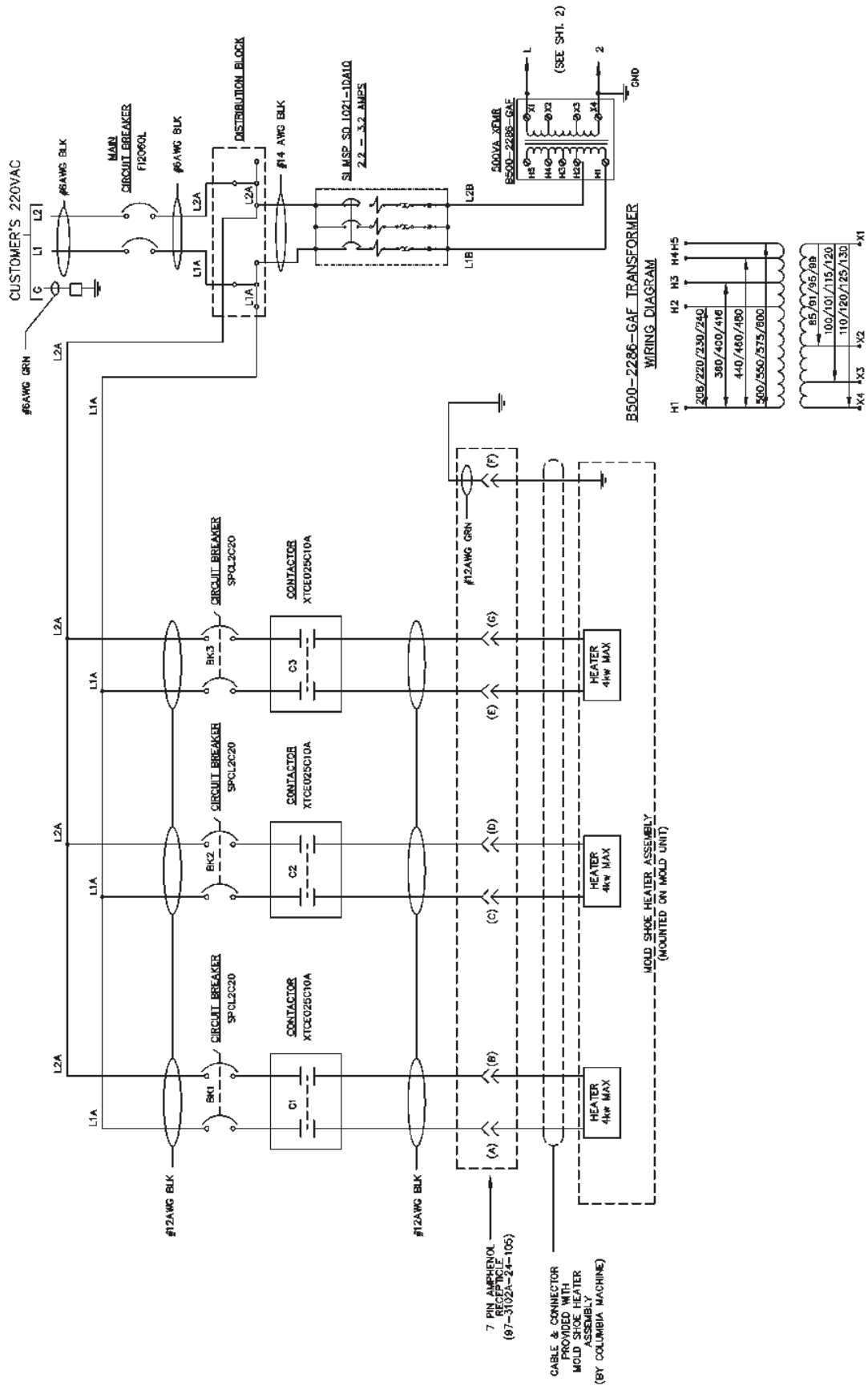

Appendix: Electrical Drawings

TIMER RELAY
H3CR-FN 100-240AC

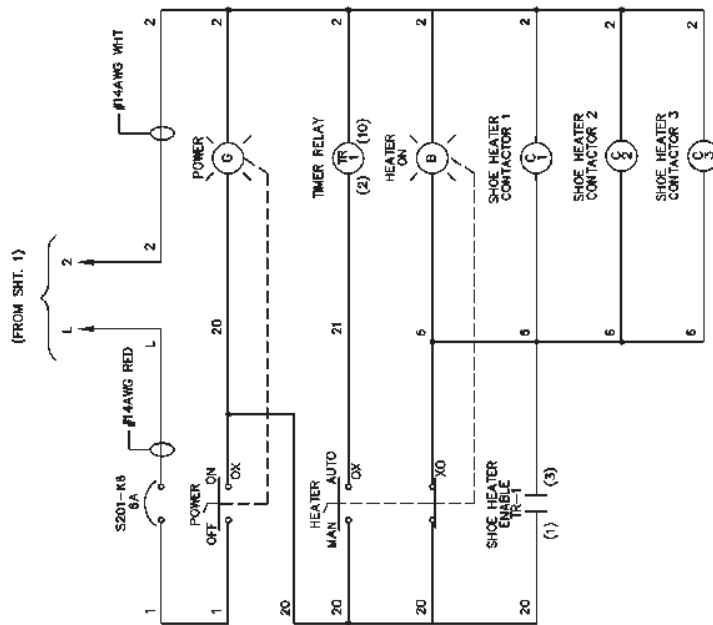

TIMER RELAY BASE WIRING DETAIL

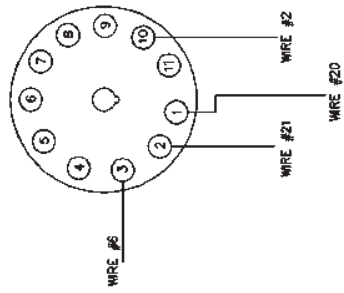

TIMER RELAY SETUP DETAIL

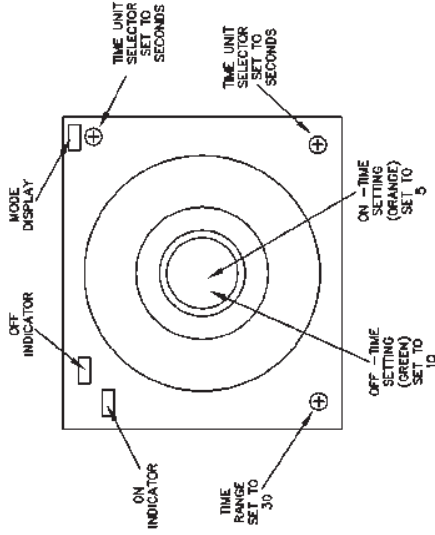

Columbia Concrete Products - Remote Temperature Controller

Appendix: Electrical Drawings

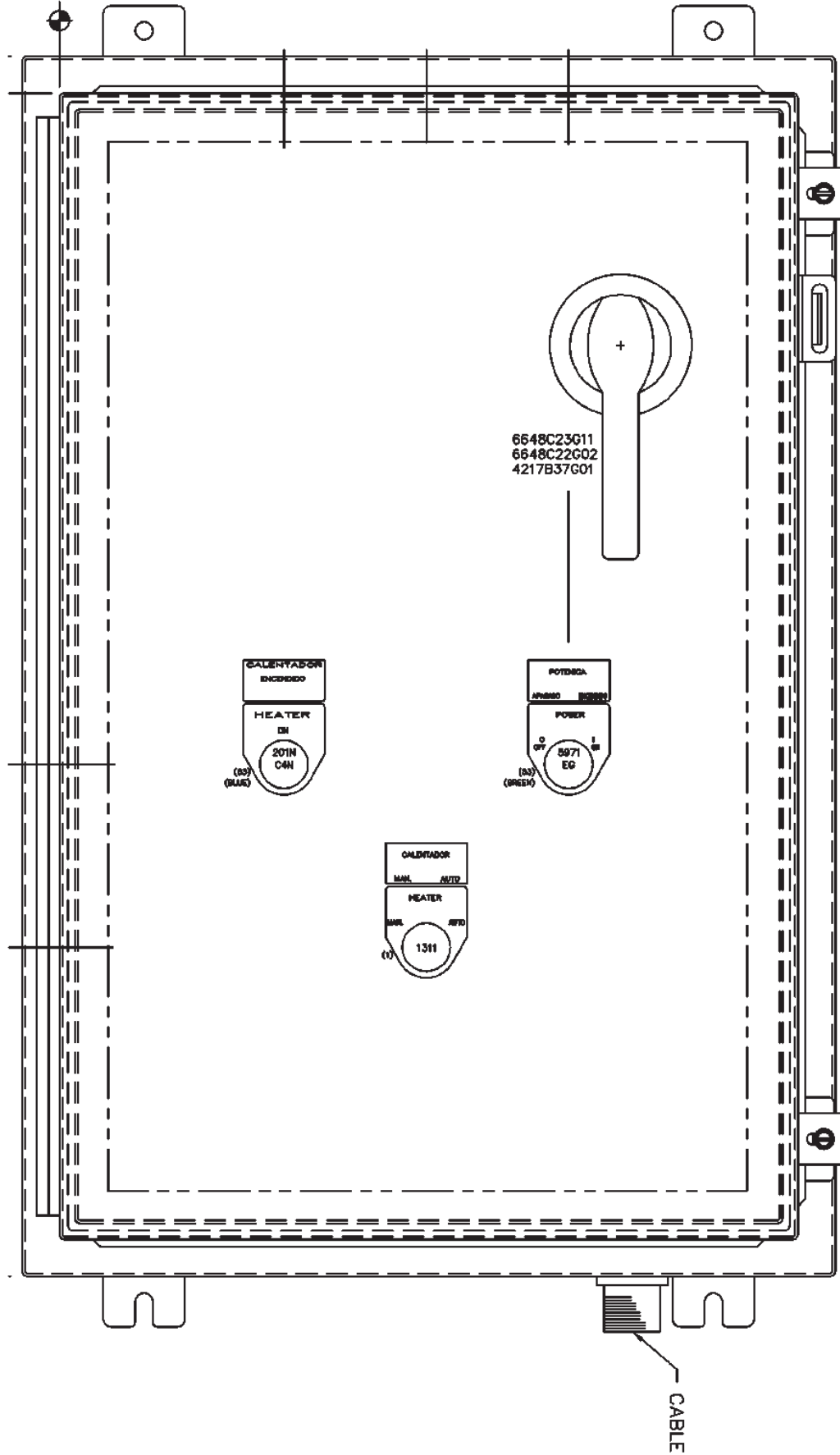

Columbia Concrete Products - Remote Temperature Controller

Appendix: Electrical Drawings

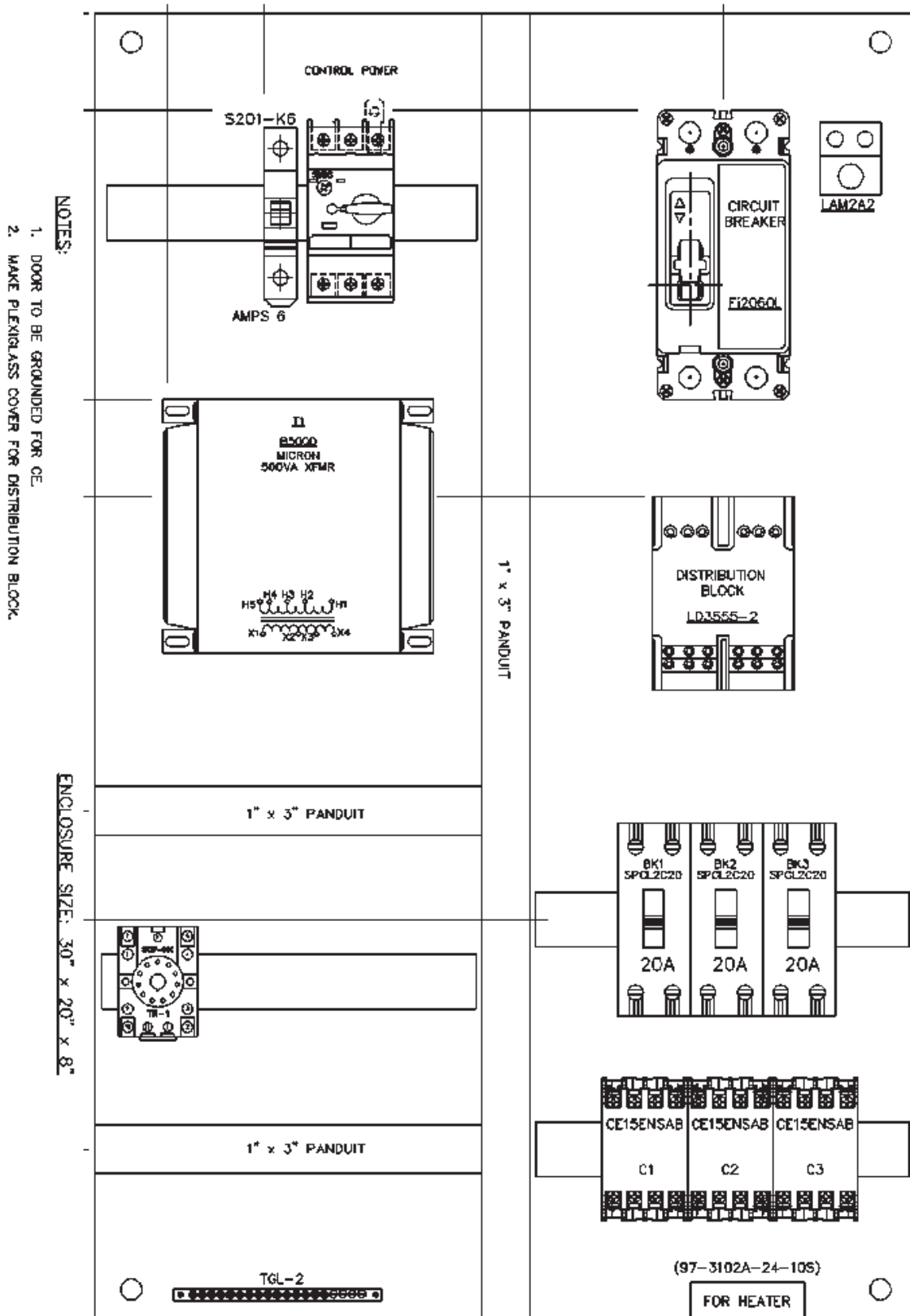

Columbia Concrete Products - Remote Temperature Controller

PARTS LIST

REMOTE TEMPERATURE CONTROLLER
(Heated Mold Shoes)
No. 601126.C

<u>No.</u>	<u>Description</u>	<u>Columbia Part Number</u>	<u>No. Req'd.</u>
1	Enclosure,30X20X8,A-302008LP	2015222	1
2	Panel F/27X17 Nema,A-30P20	2015276	1
3	Trmnl Gnd,Lam2A2/0-14-6	2010185	1
4	Dist Block Pwr,334A,Ld3555-2	2010549	1
5	Breaker Frame F,6648C23G11	2014332	1
6	Breaker Shaft 12,4217B37G01	2014329	1
7	Breaker Frame F,6648C22G02	2014103	1
8	Breaker 2Pole 60A Ce, Fi2060L	2014470	1
9	Breaker 1Pole 6A, S201-K6	2012609	1
10	Si Msp S0, 2.2-3.2 1021-1Da10	2001178	1
11	Breaker 2Pole 20A Ce, Spcl2C20	2014469	3
12	Transformer, B500-2286-Gaf	2017002	1
13	Contact, lec 2P 25	2012698	3
14	Omron Dual Timer	234202	1
15	Relay Base 11Pin,P2Cf-11	2013165	1
16	Thermometer,314F	234325	1
17	Unit,Basic Light,10250T201N	200071	1
18	Lens,Blue, 10250Tc4N	201914	1
19	Op Selector,10250T5971, 120Vac	201841	1
20	Op Knob,Green,10250TEG	200121	1
21	Op Selector,1,10250T1311	200005	1
22	Contact Block 1No/1Nc,10250T1	200190	1
23	Contact Blk,1No,10250T53	200197	1
24	Receptacle, Socket, 7 Pin	232809	1
25	Cap For Receptacles,9760-24	232811	1
26	Grounding Kit,Tgl-2	231110	1
27	Contact Blk Shroud,10250TA101	201949	8